

# HISTORY OF CONSTRUCTION

**CFR 257.73(c)(1)**

Landfill Runoff Collection Pond

Clifty Creek Plant  
Madison, Indiana

October, 2016

Prepared for: Indiana-Kentucky Electric Corporation

Prepared by: American Electric Power Service Corporation

1 Riverside Plaza

Columbus, OH 43215



**GERS-16-141**

## Table of CONTENTS

<b>1.0 OBJECTIVE</b> .....	3
<b>2.0 DESCRIPTION OF CCR THE IMPOUNDMENT</b> .....	3
<b>3.0 SUMMARY OF OWNERSHIP 257.73(c)(1)(i)</b> .....	3
<b>4.0 LOCATION OF THE CCR UNIT 257.73 (c)(1)(ii)</b> .....	3
<b>5.0 STATEMENT OF PURPOSE 257.73 (c)(1)(iii)</b> .....	4
<b>6.0 NAME AND SIZE OF WATERSHED THE CCR UNIT IS LOCATED</b> <b>257.73 (c)(1)(iv)</b>	4
<b>7.0 DESCRIPTION OF THE FOUNDATION AND ABUTMENT MATERIALS 257.73(c)(1)(v)</b> .....	4
<b>8.0 DESCRIPTION OF EACH CONSTRUCTED ZONE OR STAGE OF THE CCR UNIT 257.73 (c)(1)(vi)</b> .....	4
<b>9.0 ENGINEERING STRUCTURES AND APPURTENANCES, 257.73 (c)(1)(vii)</b> .....	5
<b>10.0 SUMMARY OF POOL SURFACE ELEVATIONS, AND MAXIMUM DEPTH OF CCR, 257.73 (c)(1)(vii)</b> .....	5
<b>11.0 FEATURES THAT COULD ADVERSELY AFFECT OPERATION DUE TO MALFUNCTION OR MIS-OPERATION (257.73 (c)(1)(vii))</b> .....	6
<b>12.0 DESCRIPTION OF THE TYPE, PURPOSE AND LOCATION OF EXISTING INSTRUMENTATION 257.73 (c)(1)(viii)</b> .....	6
<b>13.0 AREA - CAPACITY CURVES FOR THE CCR UNIT 257.73 (c)(1)(ix)</b> .....	6
<b>14.0 257.73 (c)(1)(x) DESCRIPTION OF EACH SPILLWAY AND DIVERSION</b> .....	7
<b>15.0 SUMMARY CONSTRUCTION SPECIFICATIONS AND PROVISIONS FOR SURVEILLANCE, MAINTENANCE AND REPAIR 257.73 (c)(1)(xi)</b> .....	7
<b>16.0 RECORD OR KNOWLEDGE OF STRUCTURAL INSTABILITY 257.73 (c)(1)(xii)</b> .....	7

### **Attachments**

- Attachment A – Location Map
- Attachment B – Design Drawings
- Attachment C – Instrumentation Location Map
- Attachment D – Construction Specifications

## **1.0 OBJECTIVE**

This report was prepared by AEP- Geotechnical Engineering Services (GES) section to fulfill requirements of CCR 257.73(c)(1) with an evaluation of the facility.

## **2.0 DESCRIPTION OF CCR THE IMPOUNDMENT**

The Clifty Creek Power Plant is located near the City of Madison, Jefferson County, Indiana. It is owned and operated by Indiana-Kentucky Electric Corporation (IKEC). The facility has one inactive surface impoundment called the Landfill Runoff Collection Pond (LRCP).

The LRCP dam is a cross valley dam located on a no-name tributary to the Ohio River. The dam is approximately 1,025 feet long and has a maximum height of 75 feet. Currently, the facility functions as the stormwater and leachate collection pond for the CCR landfill, and discharges to the Ohio River through a NPDES-permitted outfall.

The LRCP was constructed between 1956 and 1957 at the time when the plant was constructed. The crest elevation of the dam is 26 feet wide and at elevation 505 feet. The upstream slopes are 2.5H:1V. A stabilizing berm was constructed along the toe of the upstream slope, having a height of 10 feet and width of 100 feet due to movement of the dam in the upstream direction.

The downstream slopes are 2.5H:1V above elevation 478 feet and 3H:1V below this elevation. The crest has asphalt pavement to serve as an access road to the principal spillway, located along the right abutment hillslope.

A small saddle dike was also constructed adjacent to the LRCP dam. This dike has a crest length of 225 feet, and is approximately 17 feet high. The design slopes are 2.5H:1V. The crest elevation is also at elevation 505 feet.

## **3.0 SUMMARY OF OWNERSHIP 257.73(c)(1)(i)**

*[The name and address of the person(s) owning or operating the CCR unit: the name associated with the CCR unit: and the identification number of the CCR unit if one has been assigned by the state.]*

The LRCP at the Clifty Creek Plant is located at State Route 56, Madison, Jefferson County, Indiana. It is owned and operated by the Indiana-Kentucky Electric Corporation.

## **4.0 LOCATION OF THE CCR UNIT 257.73 (c)(1)(ii)**

*[The location of the CCR unit identified on the most recent U.S. Geological Survey (USGS) 7 ½ minute or 15 minute topographic quadrangle map, or a topographic map of equivalent scale if a USGS map is not available.]*

A location map is included in Attachment A.

## **5.0 STATEMENT OF PURPOSE 257.73 (c)(1)(iii)**

***[A statement of the purpose for which the CCR unit is being used.]***

The LRCP was initially constructed for settling and storage of fly ash. The wet disposal operations ceased around 1986 and the reservoir was converted into a dry landfill. Since then, the pond has functioned as a stormwater and leachate pond.

## **6.0 NAME AND SIZE OF WATERSHED THE CCR UNIT IS LOCATED**

### **257.73 (c)(1)(iv)**

***[The name and size in acres of the watershed within which the CCR unit is located.]***

The LRCP is located in the Silver-Little Kentucky Watershed (HUC 05140101), which is 811,706 acres (1,268.29 square miles). The watershed to the LRCP is approximately 510 acres, consisting of primarily wooded hillsides, portions of the CCR landfill and some off site drainage.

## **7.0 DESCRIPTION OF THE FOUNDATION AND ABUTMENT MATERIALS**

### **257.73(c)(1)(v)**

***[A description of the physical and engineering properties of the foundation and abutment materials on which the CCR unit is located.]***

The LRCP dam was constructed on the natural soils, and the abutment consists of the hillslope of the Devils Backbone Ridge at the left abutment and natural ground on the right abutment. A subsurface investigation was conducted in 2009, and the strength parameters of the foundation, as well as the embankment were defined based on laboratory tests or correlations to known strengths based on blow counts. The foundation materials are described as lean clay with sand and a relative density of very soft to medium stiff. The bedrock beneath the foundation soils is described as weathered gray shale. Results of laboratory testing of the foundation soils yield strength parameters of 27 degrees and 160 psf cohesion.

The geotechnical reports related to the safety factor assessment provide more specific properties of the foundation and embankment materials. Based on these reports, the foundation materials are adequate to support this facility.

## **8.0 DESCRIPTION OF EACH CONSTRUCTED ZONE OR STAGE OF THE CCR UNIT**

### **257.73 (c)(1)(vi)**

***[A statement of the type, size, range, and physical and engineering properties of the materials used in constructing each zone or stage of the CCR unit; and the approximate dates of construction of each successive stage of construction of the CCR unit.]***

The LRCP dam was constructed as a homogenous dam. The materials of construction consisted of native sandy, lean clay soils. There is no formal design report for this facility. However, the overall design parameters were defined by Casagrande Consultants.

Construction was completed in 1957. The compacted embankment material was tested and has strength values of 33 degrees and 165 psf cohesion.

Based on these reports, the site investigation and test results, the embankment materials are adequate to support this facility.

**9.0 ENGINEERING STRUCTURES AND APPURTENANCES, 257.73 (c)(1)(vii)**

*[At a scale that details engineering structures and appurtenances relevant to the design, construction, operation, and maintenance of the CCR unit, detailed dimensional drawings of the CCR unit, including a plan view and cross sections of the length and width of the CCR unit, showing all zones, foundation improvements, drainage provisions, spillways, diversion ditches, outlets, instrument locations, and slope protection...]*

The primary spillway is a sloping concrete shaft connected to a 72-inch diameter, reinforced concrete pipe, which regulates normal flow conditions. There is no emergency spillway. The engineering drawings of the engineering structures and appurtenances are included in Attachment B.

As described previously, the LRCP dam is a cross valley dam, so there are no diversion ditches.

Slope protection along the inboard slope consists primarily of riprap over the compacted embankment. The outboard slope has grass vegetation for the entire slope.

**10.0 SUMMARY OF POOL SURFACE ELEVATIONS, AND MAXIMUM DEPTH OF CCR, 257.73 (c)(1)(vii)**

*[...in addition to the normal operating pool surface elevation and the maximum pool elevation following peak discharge from the inflow design flood, the expected maximum depth of CCR within the CCR surface impoundment.]*

The table below describes the normal pool elevations and maximum pool elevations, as well as maximum depth of CCR within the impoundment. The facility is considered a significant hazard potential classification. The corresponding design flood is the 1,000-year event. The flood routing evaluation is based on the PMF, which has a rainfall value (27.6 inches in 6 hours) greater than the 1,000-year rainfall value (7.19 inches in 6 hours). Additional information is contained in the Inflow Design Flood Control Plan for this CCR unit.

	<b>South fly ash pond</b>
Dam Crest Elevation (ft)	505
Normal Pool Elevation/max. operating(ft)	486
Maximum Pool Elevation (ft) following peak discharge from inflow design flood (full PMF)	501.4
Expected Maximum depth of CCR within impoundment	60

**11.0 FEATURES THAT COULD ADVERSELY AFFECT OPERATION DUE TO MALFUNCTION OR MIS-OPERATION (257.73 (c)(1)(vii))**

*[...and any identifiable natural or manmade features that could adversely affect operations of the CCR unit due to malfunction or mis-operation]*

During an extreme flood event, natural debris may tend to collect in front of the concrete tower and block flow from being discharge. There is a floating skimmer structure in front to minimize any potential blockage.

**12.0 DESCRIPTION OF THE TYPE, PURPOSE AND LOCATION OF EXISTING INSTRUMENTATION 257.73 (c)(1)(viii)**

*[A description of the type, purpose, and location of existing instrumentation.]*

The LRCP dam has 7 piezometers located within the structure of the dam. These piezometers are read on a minimum of every 30 days for the purpose of determining the phreatic water level within the dike. An instrumentation location map is provided in Attachment C.

**13.0 AREA – CAPACITY CURVES FOR THE CCR UNIT 257.73 (c)(1)(ix)**

*[Area-capacity curves for the CCR unit.]*

The area capacity table is shown below.

**Table 2. LRCP Stage-Storage – Existing Conditions**

<b>Elevation (feet)</b>	<b>LRCP Storage (acre-feet)</b>
440	0.0
445	14.7
450	62.7
455	170.5
460	353.0
465	590.2
470	871.9
475	1,198.0
480	1,491.9
485	1,549.2
490	1,737.5
495	1,965.0
500	2,248.9
504	2,560.8

#### **14.0 257.73 (c)(1)(x) DESCRIPTION OF EACH SPILLWAY AND DIVERSION**

***[A description of each spillway and diversion design features and capacities and calculations used in their determination.]***

The primary spillway is a sloping concrete tower shaft connected to a 72-inch diameter reinforced concrete pipe which regulates normal flow conditions.

Complete details of each spillway structure are included with the design drawings in Attachment B. Hydrology and Hydraulic Analysis which include calculations for each spillway structure are included in Inflow Design Flood Control Plan (separate from this report).

#### **15.0 SUMMARY CONSTRUCTION SPECIFICATIONS AND PROVISIONS FOR SURVEILLANCE, MAINTENANCE AND REPAIR 257.73 (c)(1)(xi)**

***[The construction specifications and provisions for surveillance, maintenance, and repair of the CCR unit.]***

There are no construction specifications in the historic files for this facility. As noted, Casagrande Consultants provided recommendations for design parameters.

As required by the CCR rule, the LRCP dam is inspected at least every 7 days by a qualified person. Instrumentation data is collected at least every 30 days and reviewed by AEP Engineering Services. Also as a requirement of the CCR rule, the impoundment is also inspected annually by a professional engineer.

If repairs are found to be necessary during any inspection they will be completed as needed.

#### **16.0 RECORD OR KNOWLEDGE OF STRUCTURAL INSTABILITY 257.73 (c)(1)(xii)**

***[Any record or knowledge of the structural instability of the CCR unit.]***

To date there has been no record of knowledge of the structural instability of the CCR unit since the facility started operations.

**ATTACHMENT A**

**LOCATION MAP**



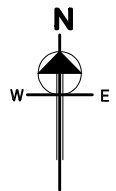
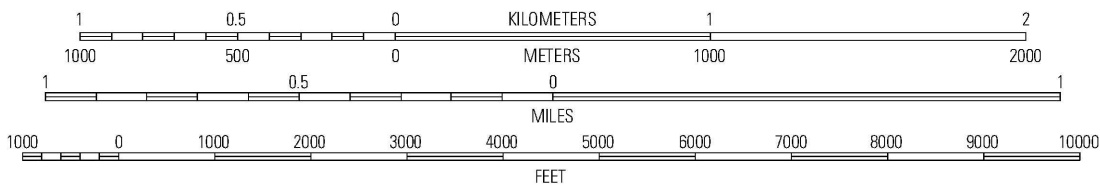
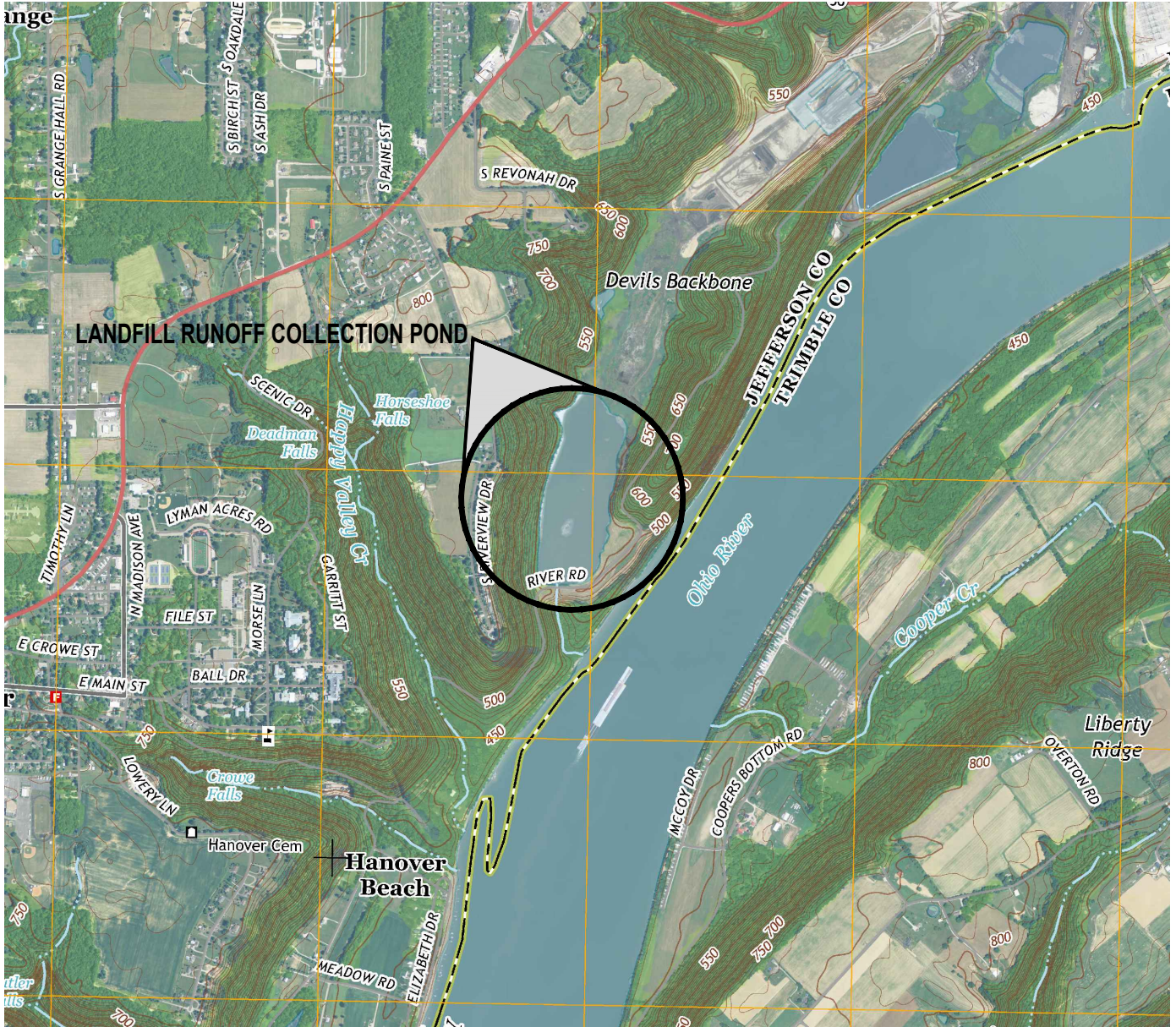

THIS DRAWING IS CLASSIFIED AS:

**AEP PUBLIC**

REFERENCE AEP'S CORPORATE INFORMATION SECURITY POLICY

"THIS DRAWING IS THE PROPERTY OF THE **AMERICAN ELECTRIC POWER SERVICE CORP.** AND IS LOANED UPON CONDITION THAT IT IS NOT TO BE REPRODUCED OR COPIED, IN WHOLE OR IN PART, OR USED FOR FURNISHING INFORMATION TO ANY PERSON WITHOUT THE WRITTEN CONSENT OF THE **AEP SERVICE CORP.** ,OR FOR ANY PURPOSE DETRIMENTAL TO THEIR INTEREST, AND IS TO BE RETURNED UPON REQUEST"

INDIANA-KENTUCKY ELECTRIC CORPORATION

**CLIFTY CREEK PLANT**

MADISON

INDIANA

LANDFILL RUNOFF COLLECTION POND  
**USGS TOPO MAP**  
 7.5-MINUTE SERIES

UNIT:  
16

DRAWING NUMBER:  
LOCATION MAP

REV:  
1

SCALE: 1"=2000'

CIVIL ENGINEERING

DR:

CH:

SUP:

ENG:

DATE: 10/10/16



**AEP SERVICE CORP.**  
 1 RIVERSIDE PLAZA  
 COLUMBUS, OH 43215

**ATTACHMENT B**

**DESIGN DRAWINGS**

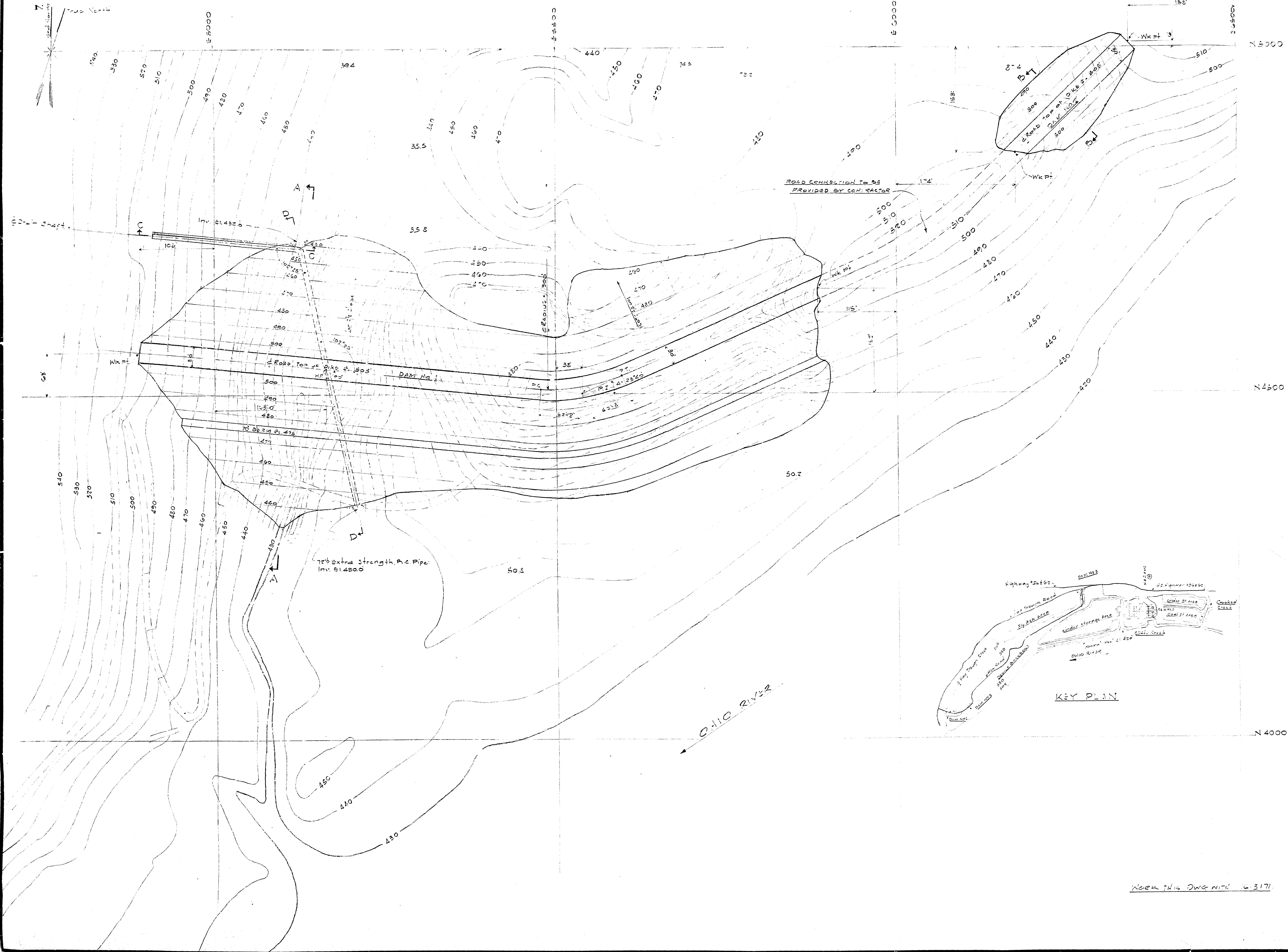

GENERAL NOTES  
For Notes see Dwg. B-171

MATERIAL  
72" Dia. P.C. Pipe 24000  
72" Dia. P.C. Pipe 4000  
72" Dia. P.C. Pipe 20000

REFERENCE  
16 B-171 Earth Dam Section

Map of Survey by Gordon R. Noris & Assoc.

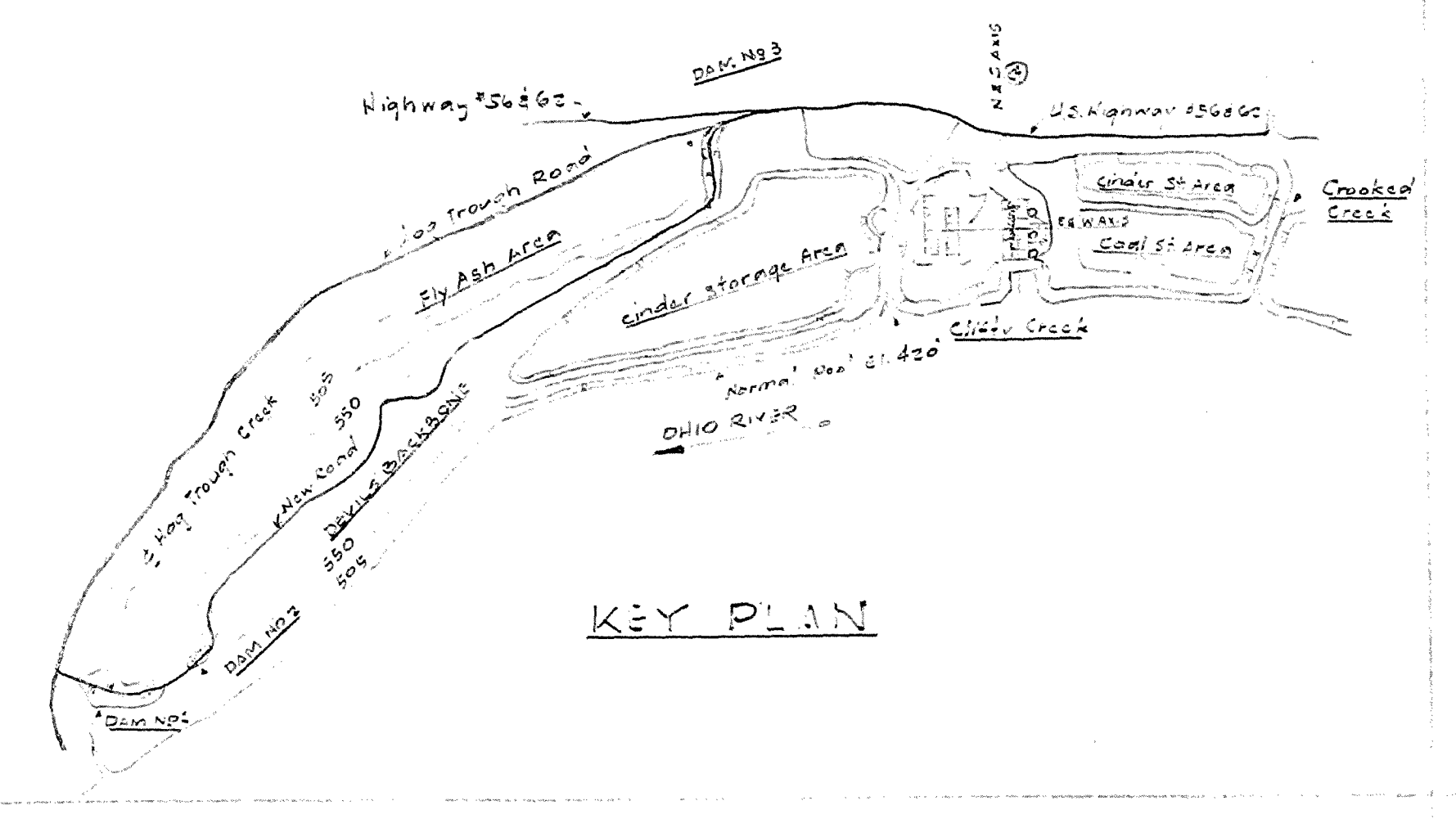

KEY PLAN

Check this Dwg with 16.317.1

DATE	NO.	DESCRIPTION	APPR.
4-24-56	1	Relocated origin station 10+00 to 5+00	55

**REVISIONS**

ELY ASH AREA  
LOWER PART DAVIS NO. 142 PLAN

INDIANA KENTUCKY ELECTRIC CORP.  
CLIFTY CREEK PLANT  
MADISON INDIANA

DR. NO. 16.317.1

ARCH.	ELEC.	MECH.	STR.

SCALE 1" = 50'

DR. No. 16.317.1

CH. 16.317.1

DATE 4-2-56

APPROVED 55

AMERICAN GAS & ELECTRIC SERVICE CORP.  
30 CHURCH STREET NEW YORK

Clay should be compacted to a minimum thickness of 4" in compacted layers. When compacted with a mechanical roller, a test pressure of at least 200 lbs. per sq. in. should be obtained. This minimum test pressure should be obtained on the surface of the clay in the field. Whenver this test is made, it should be noted whether the roller reduces the water content of the clay or not. The surface of the clay should be crowned such that no water can drain readily toward the outside slope. In addition, wherever a heavy rain threatens the surface, the surface should be smoothed with a smooth roller to reduce the amount of water which will be absorbed by the clay. A grass cover or other type of vegetative stabilizer should be provided on the slope immediately after construction and maintained until a satisfactory state of growth has developed. See further information on Clay Compaction's letter of Feb. 10, 1935.

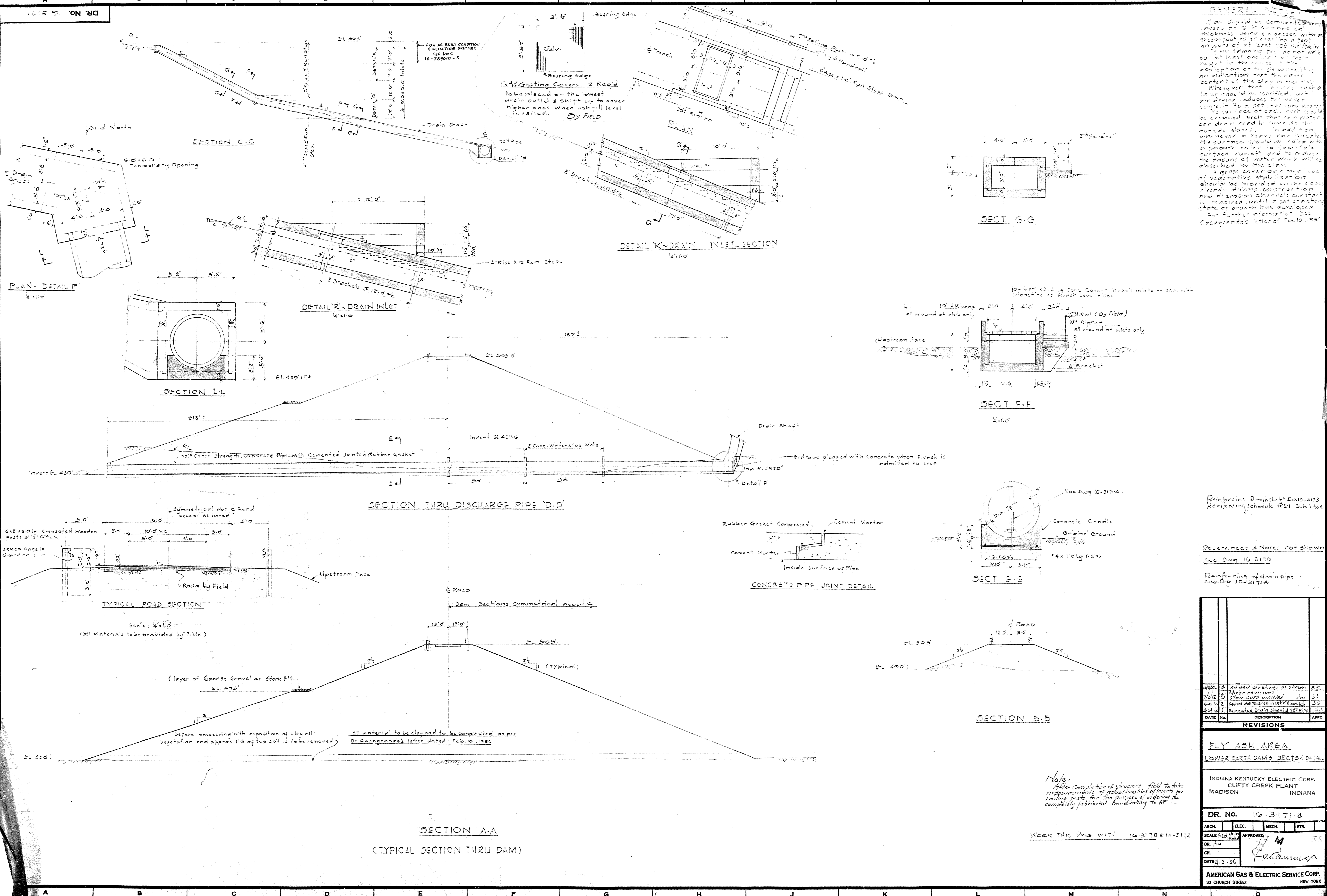

Reinforcing Drain Inlet - DWG 16-3171-4  
Reinforcing Schedule RS-1 Sht. 1 of 4

References & Notes not shown  
See DWG 16-3170

Reinforcing of drain pipe -  
See DWG 16-3171A

NO.	DATE	DESCRIPTION	BY	APPD.
1	7/15/36	Added section at stream	S.B.	
2	7/15/36	Minor revision	J.S.	
3	7/15/36	Stair curb omitted	J.S.	
4	6-16-36	Revised wall thickness in DETAIL SECTION	J.S.	
5	6-16-36	Revised Drain Inlet - 4" x 12" x 12"	J.S.	

**REVISIONS**

**FLY ASH AREA**

LOWER EARTH DAMS SECTIONS & DETAILS

INDIANA KENTUCKY ELECTRIC CORP.  
CLIFTY CREEK PLANT  
MADISON INDIANA

DR. No. 16-3171-4

ARCH.	ELEC.	MECH.	STR.
SCALE 1/2" = 1'-0"	APPROVED		
DR. J.S.	<i>[Signature]</i>		
CH.			
DATE 2-2-36			

AMERICAN GAS & ELECTRIC SERVICE CORP.  
30 CHURCH STREET NEW YORK

Note:  
After completion of structure, field to take measurements of actual location of inlets for railing posts for the purpose of explaining the completely fabricated hand-railing to fit.

Keep this drawing with 16-3170 & 16-3173

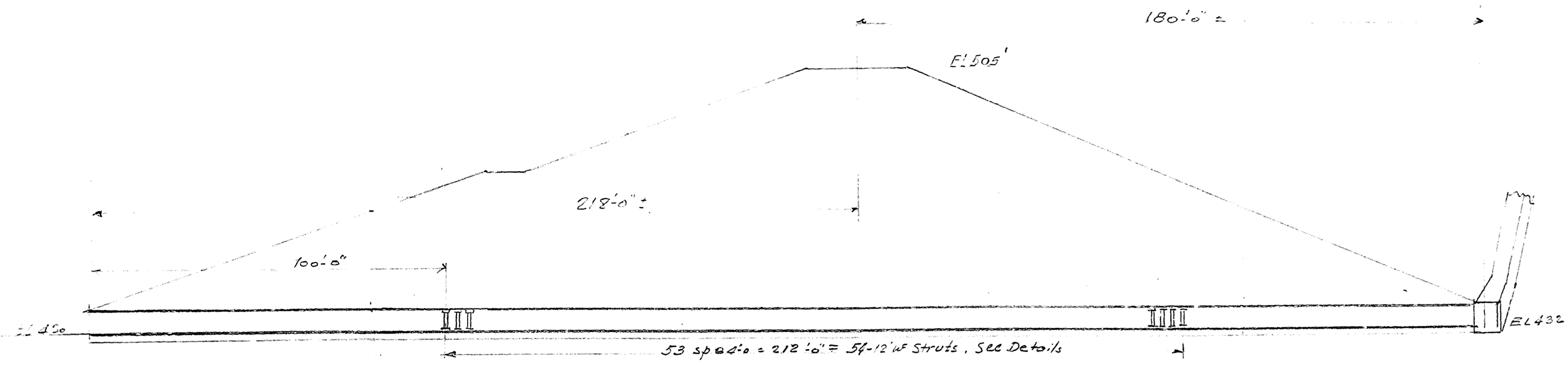

SECTION THRU DAM AT 6'-0" ID DRAIN  
SCALE 1" = 40'-0"

STRUTS TO BE GIVEN ONE (1) COAT OF BITUMASTIC PRIME AND BE LEFT PERMANENTLY IN PLACE.

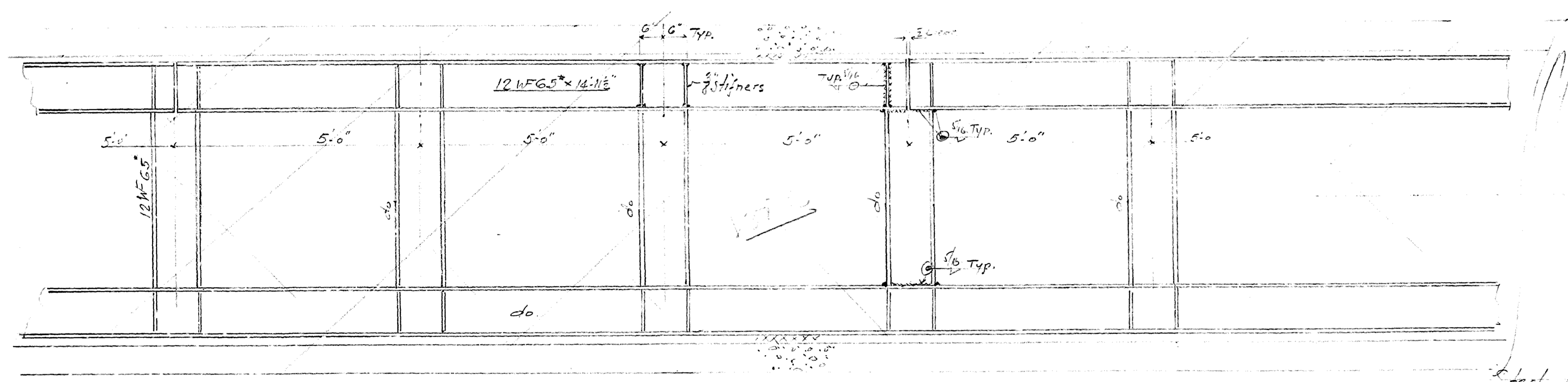

SCALE 2 1/2" = 1'-0"

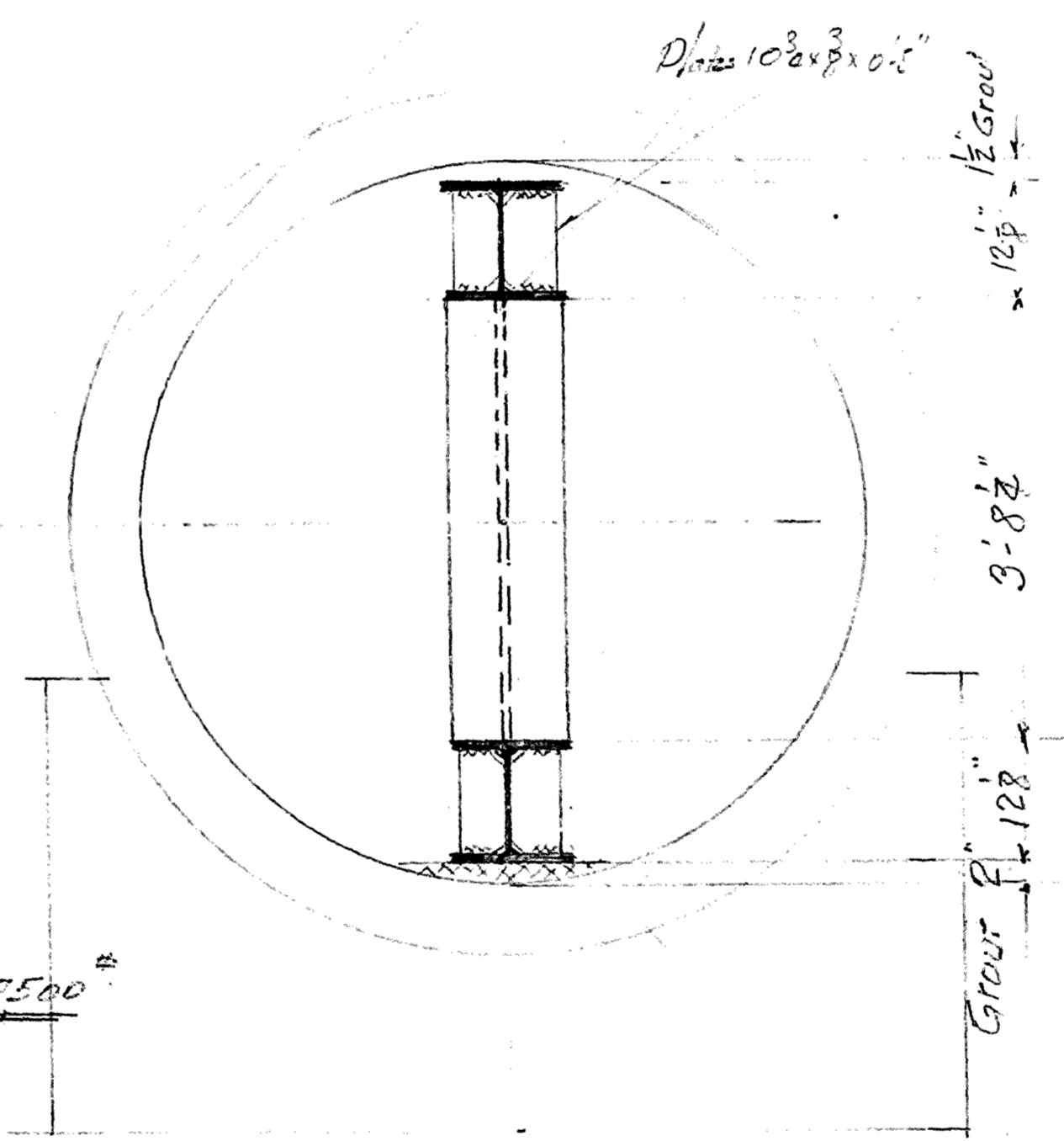

Section detail of Drain shaft and 6'-0" ID drain see Dr. 16-3171

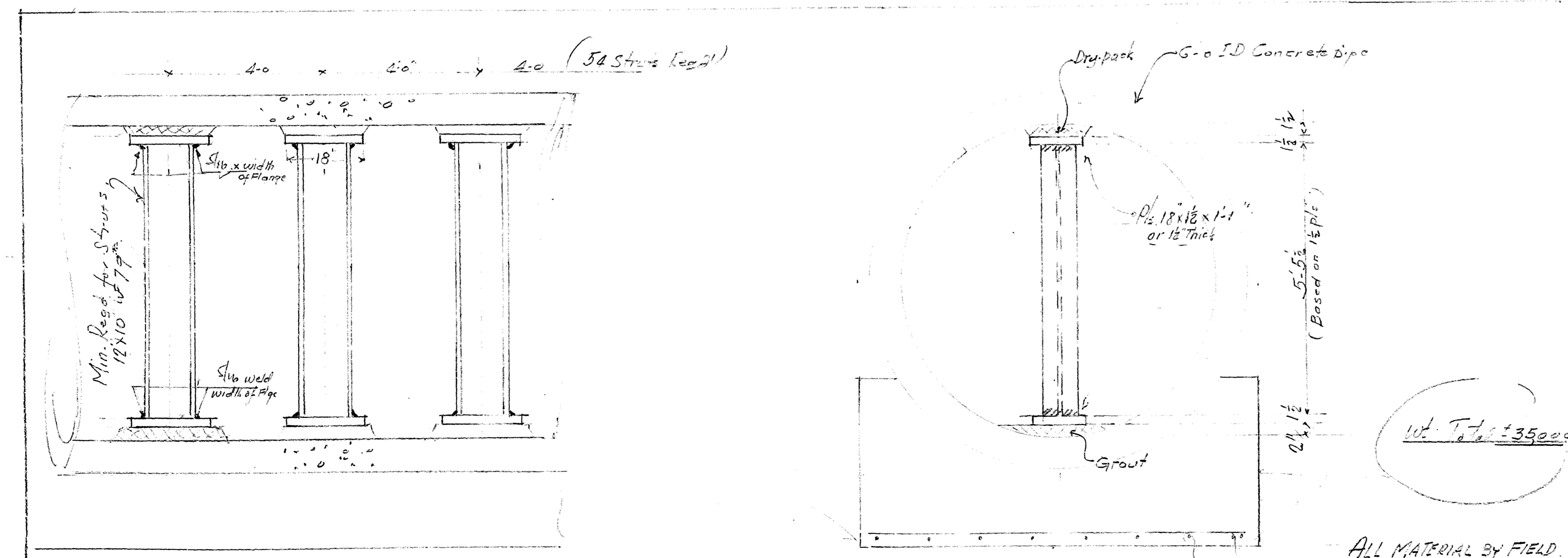

Typical longitudinal Section

SCALE 3/4" = 1'-0"

ALL MATERIAL BY FIELD.

DATE	NO.	DESCRIPTION	APPD.
		Adopt Note & Revised Weight on SS	
<b>REVISIONS</b>			
FLY ASH AREA LOWER EARTH DAM 6'-0" DRAIN REINFORCING			
INDIANA KENTUCKY ELECTRIC CORP. CLIFTY CREEK PLANT MADISON INDIANA			
DR. NO. 16-3171A-1			
ARCH.	ELEC.	MECH.	STR.
SCALE: (Notes) APPROVED			
DATE: 6/28/58			
AMERICAN GAS & ELECTRIC SERVICE CO. 30 CHURCH STREET NEW YORK			

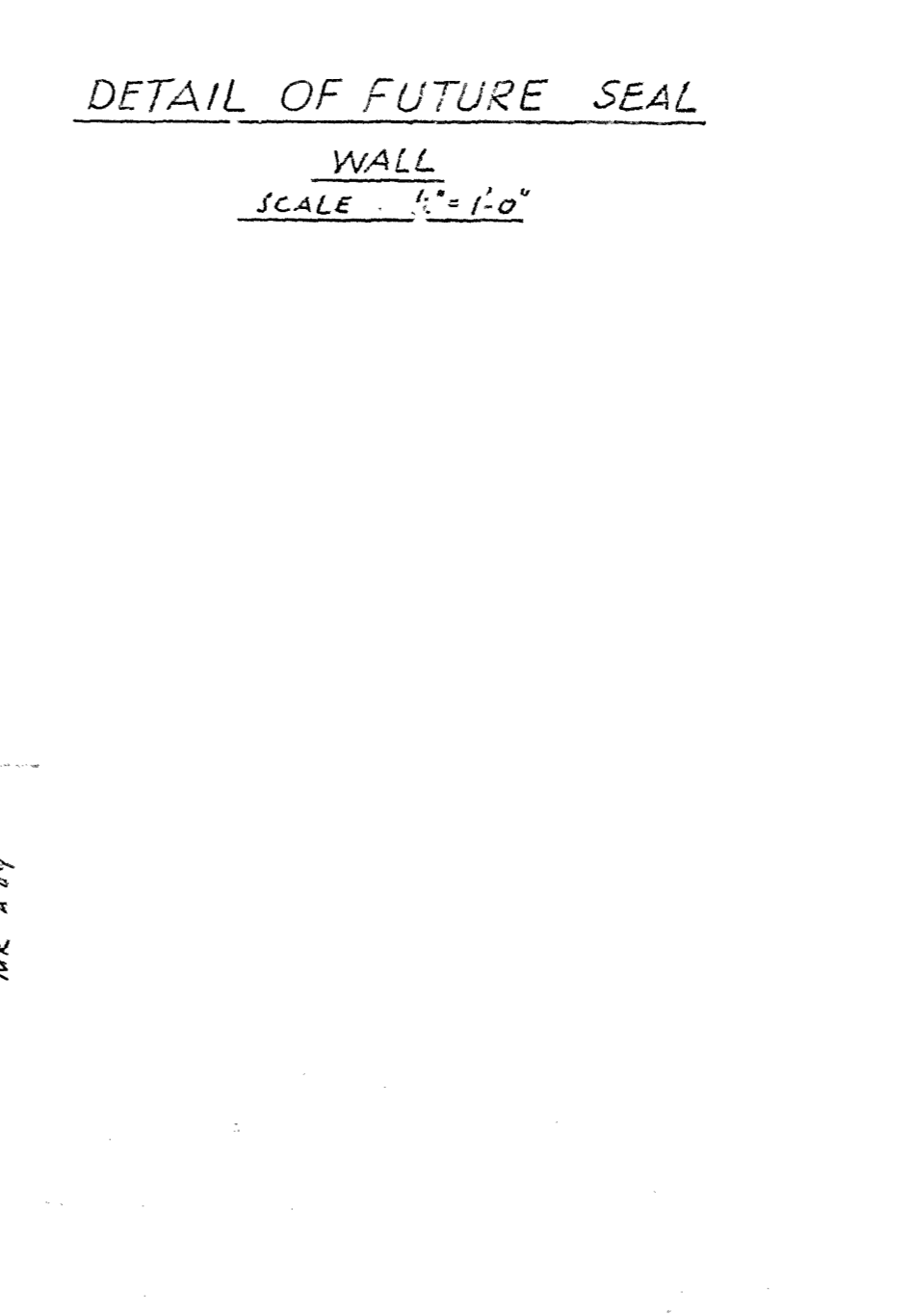
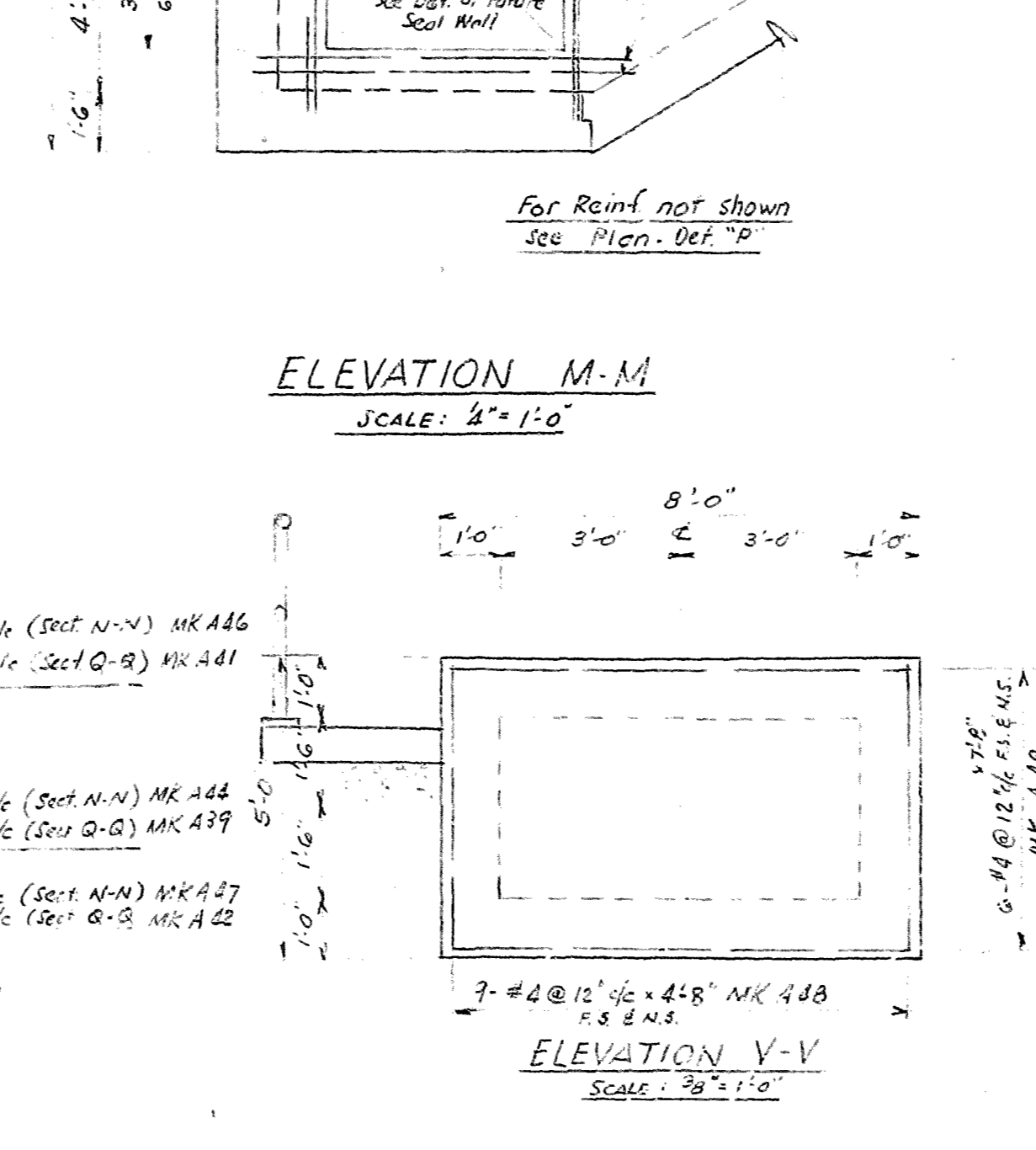
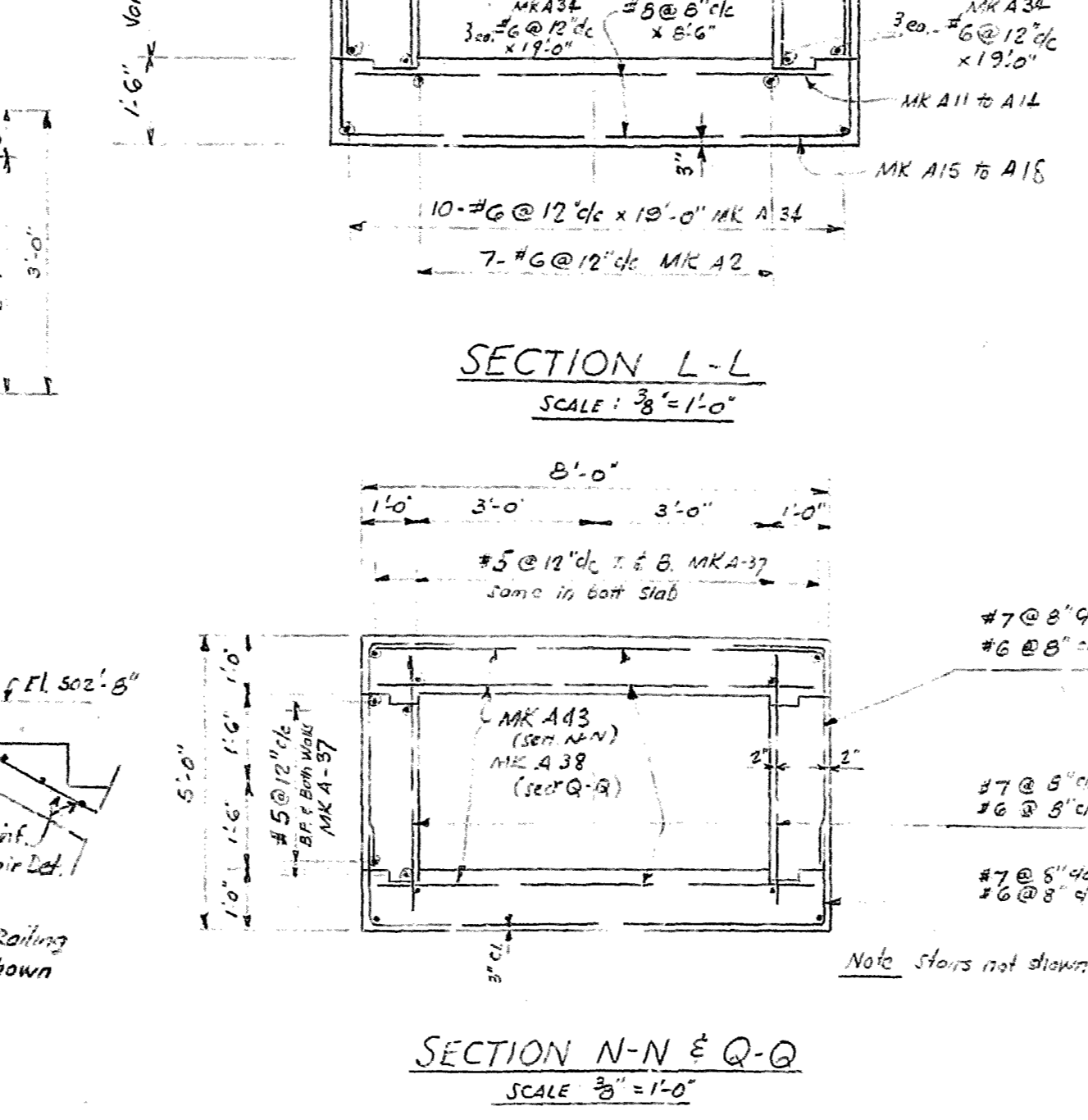
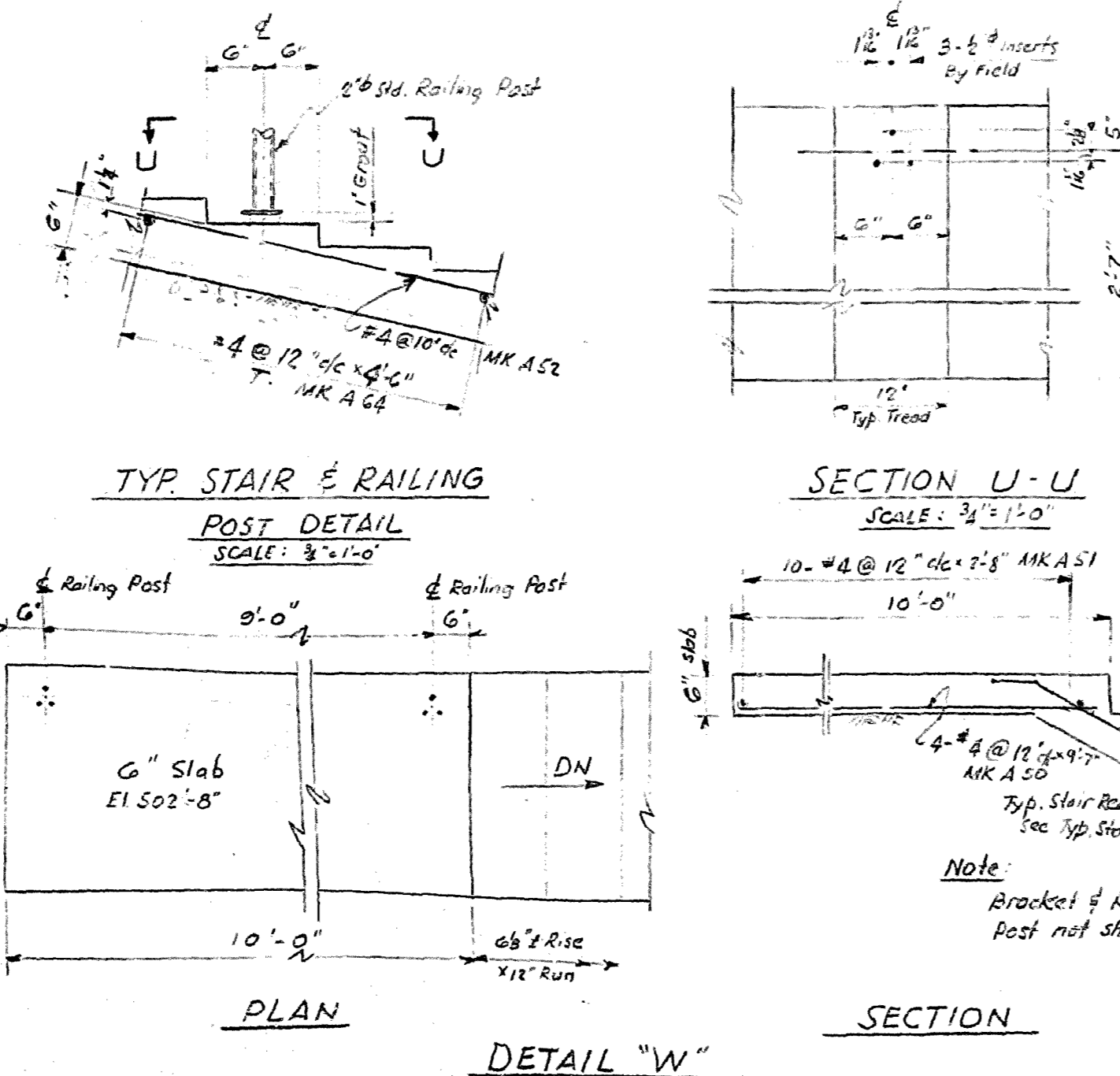
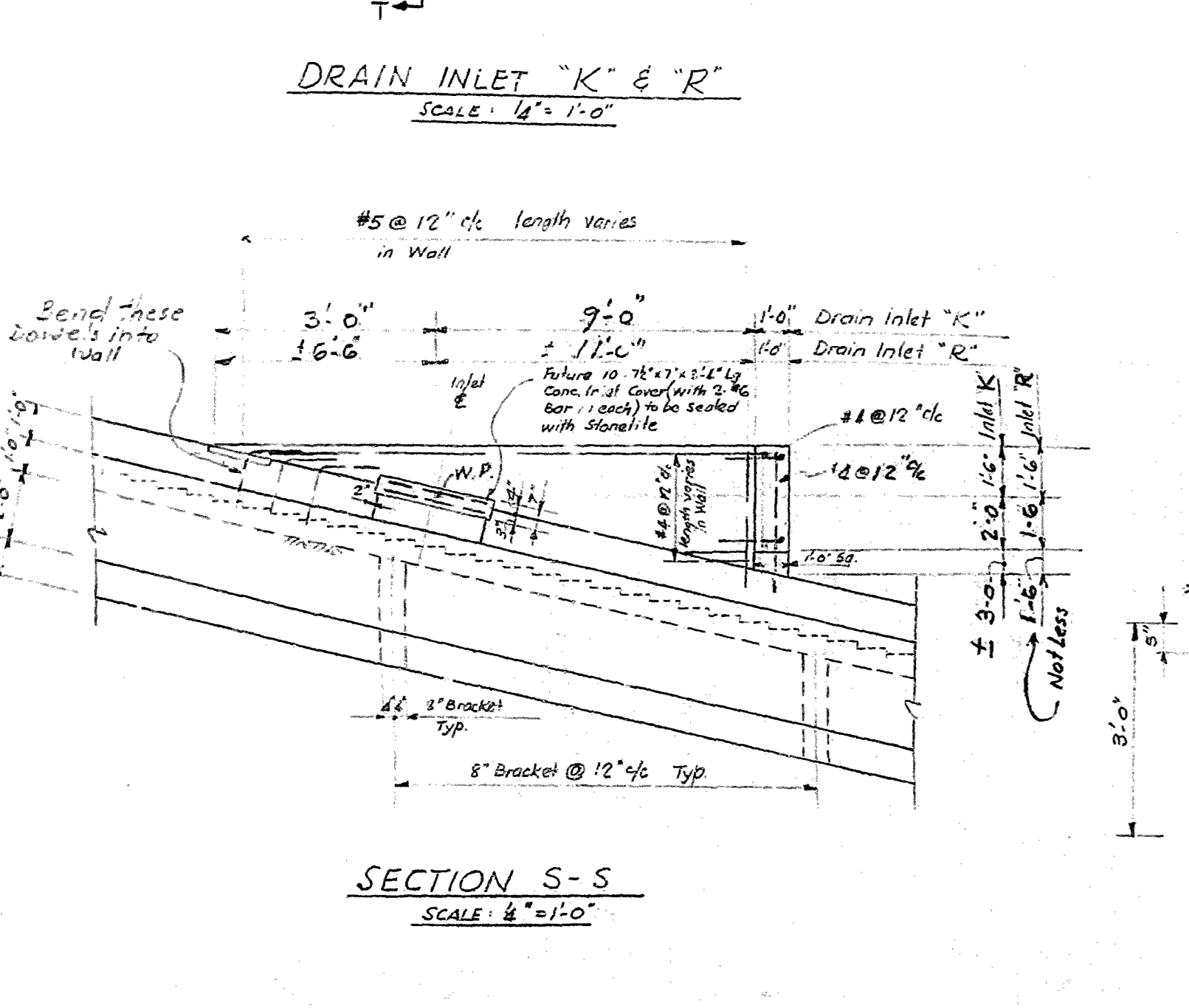
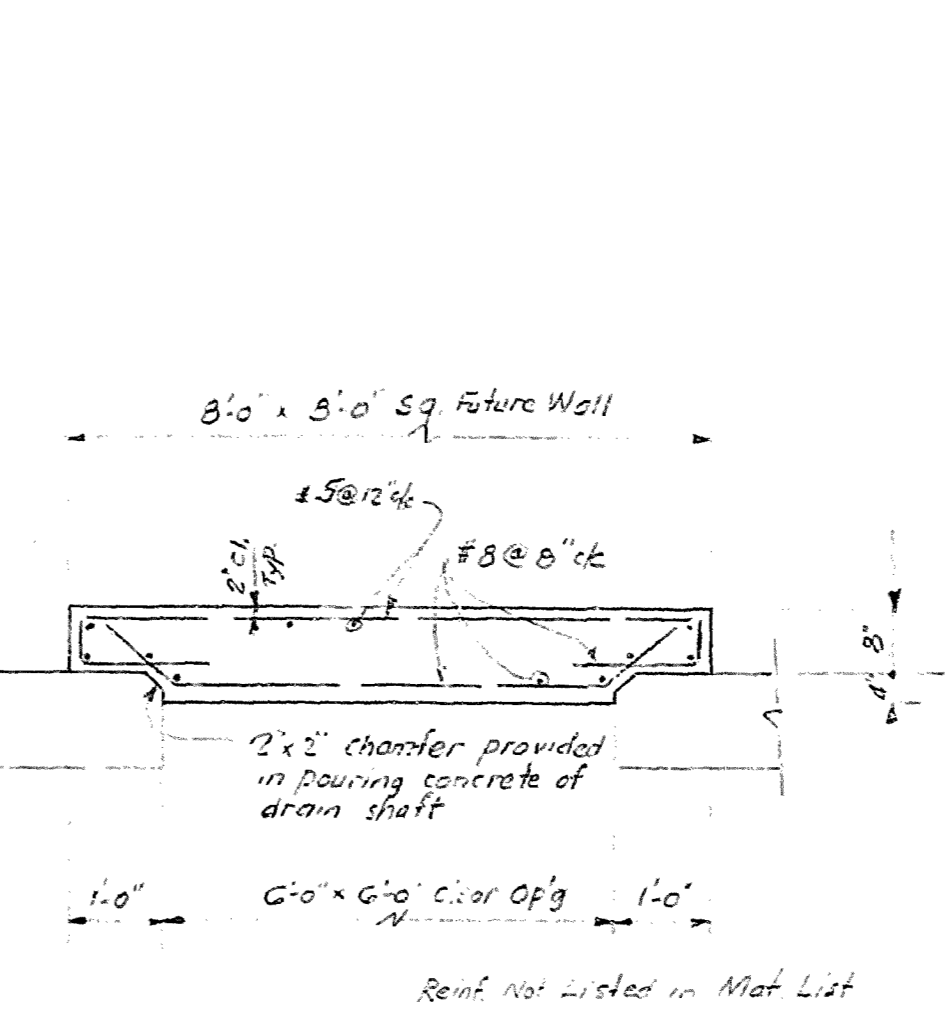
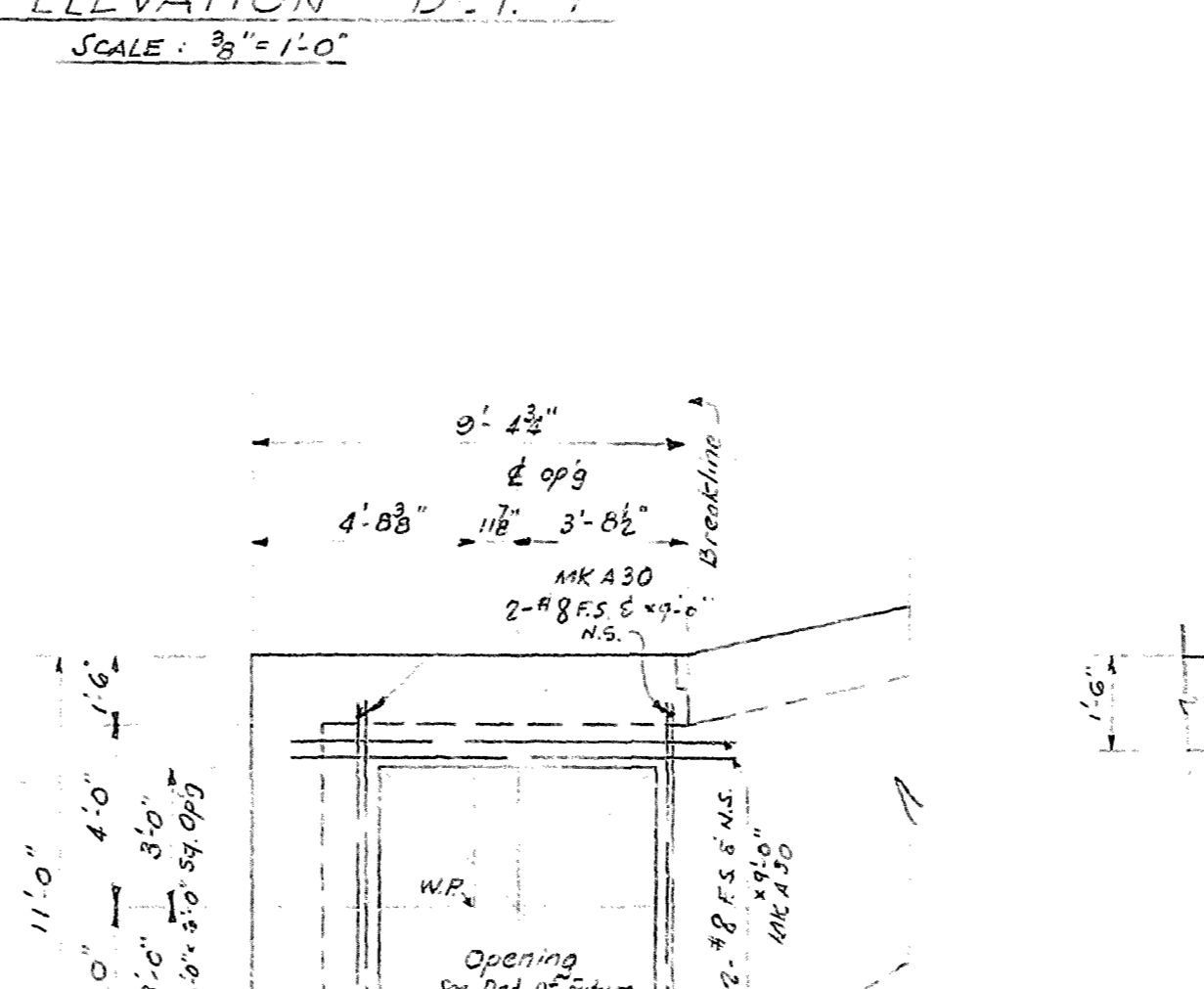
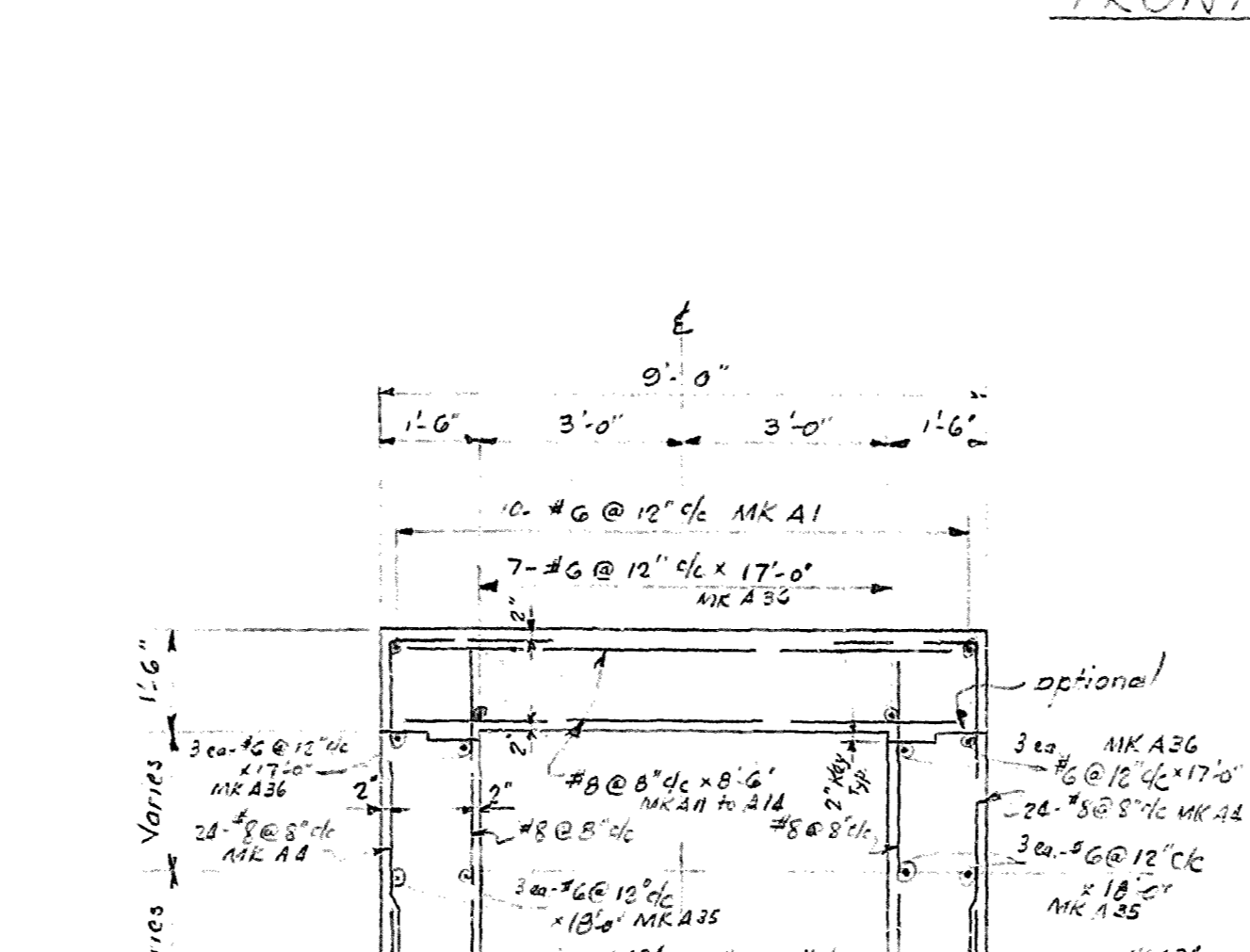
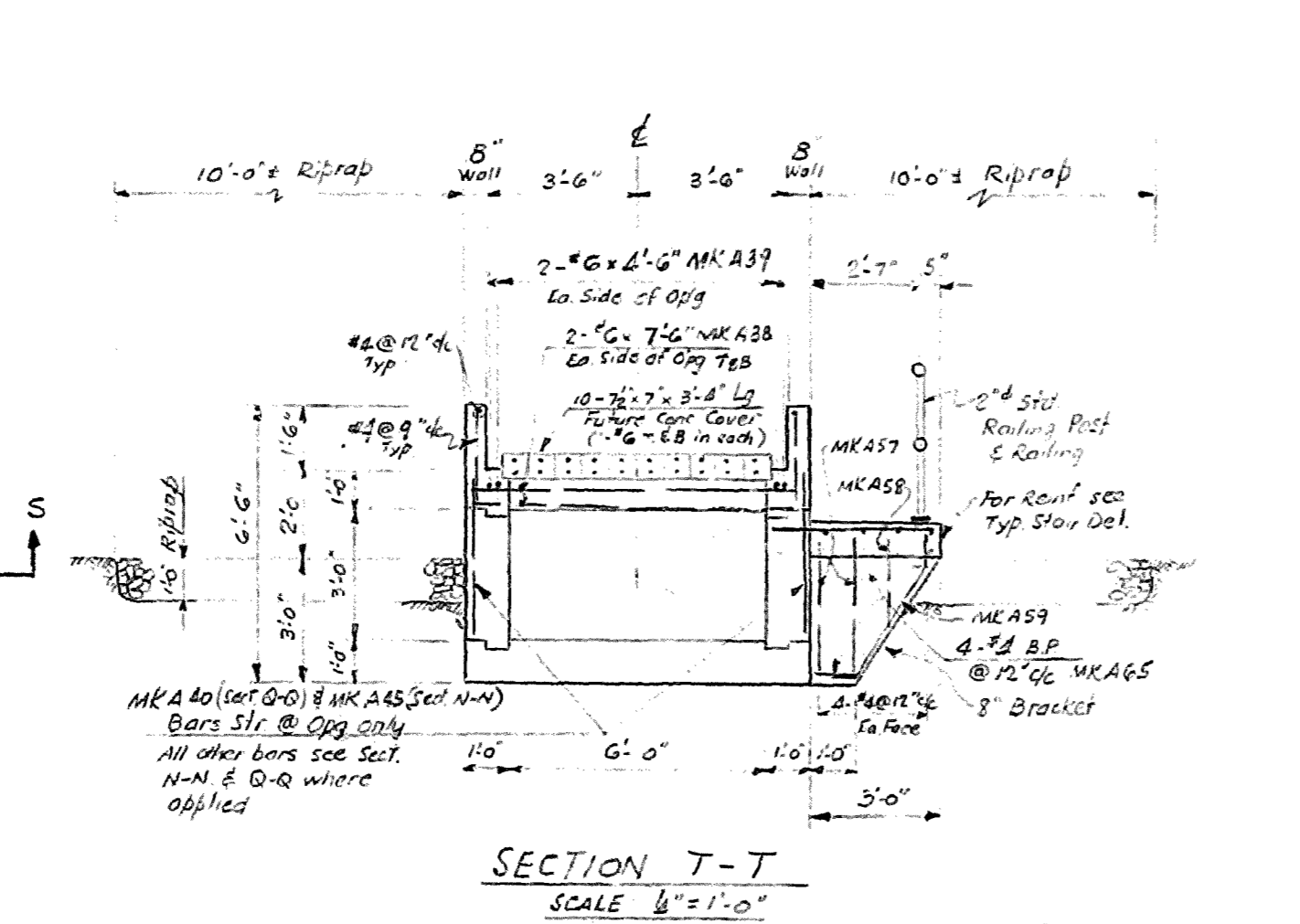
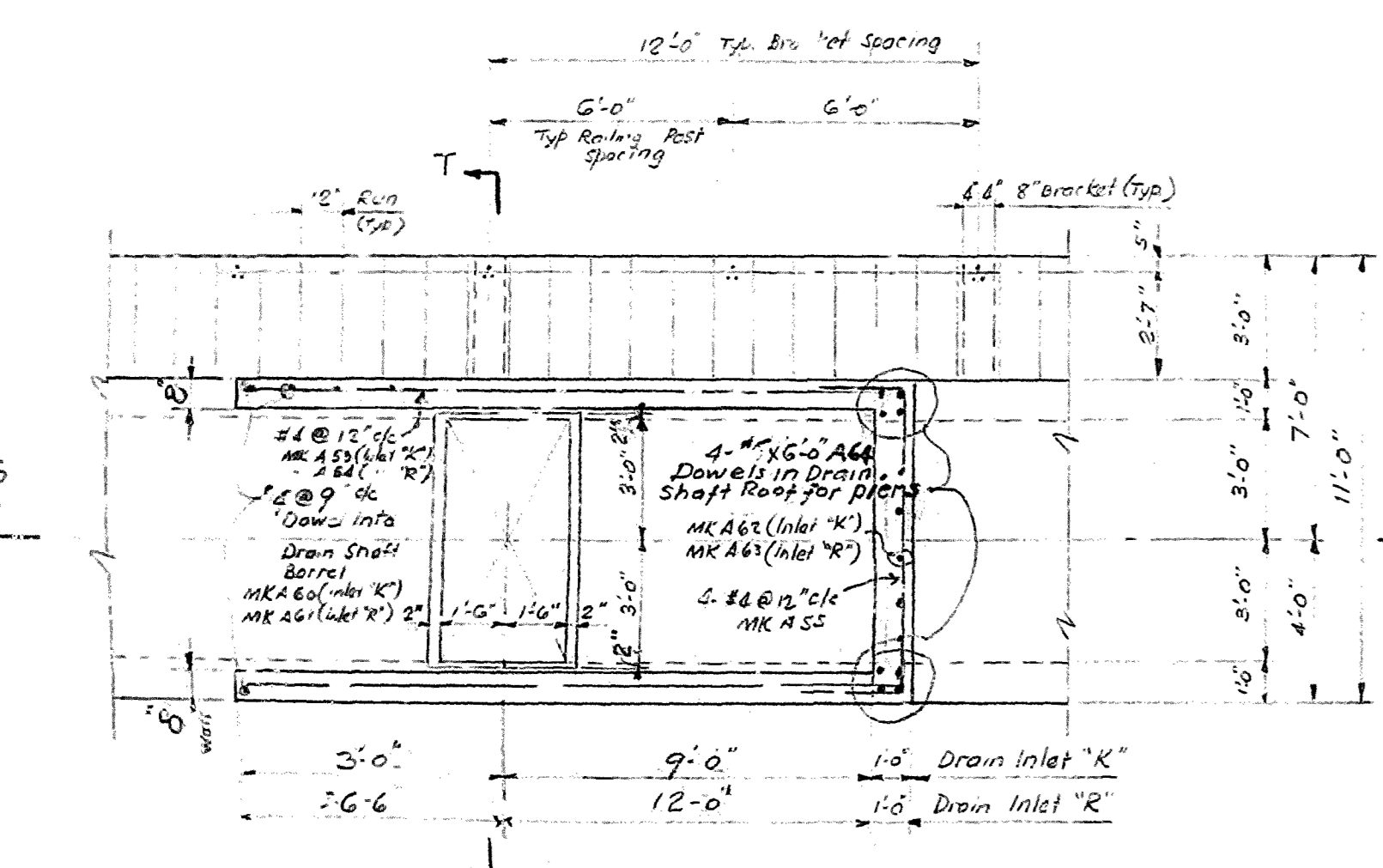
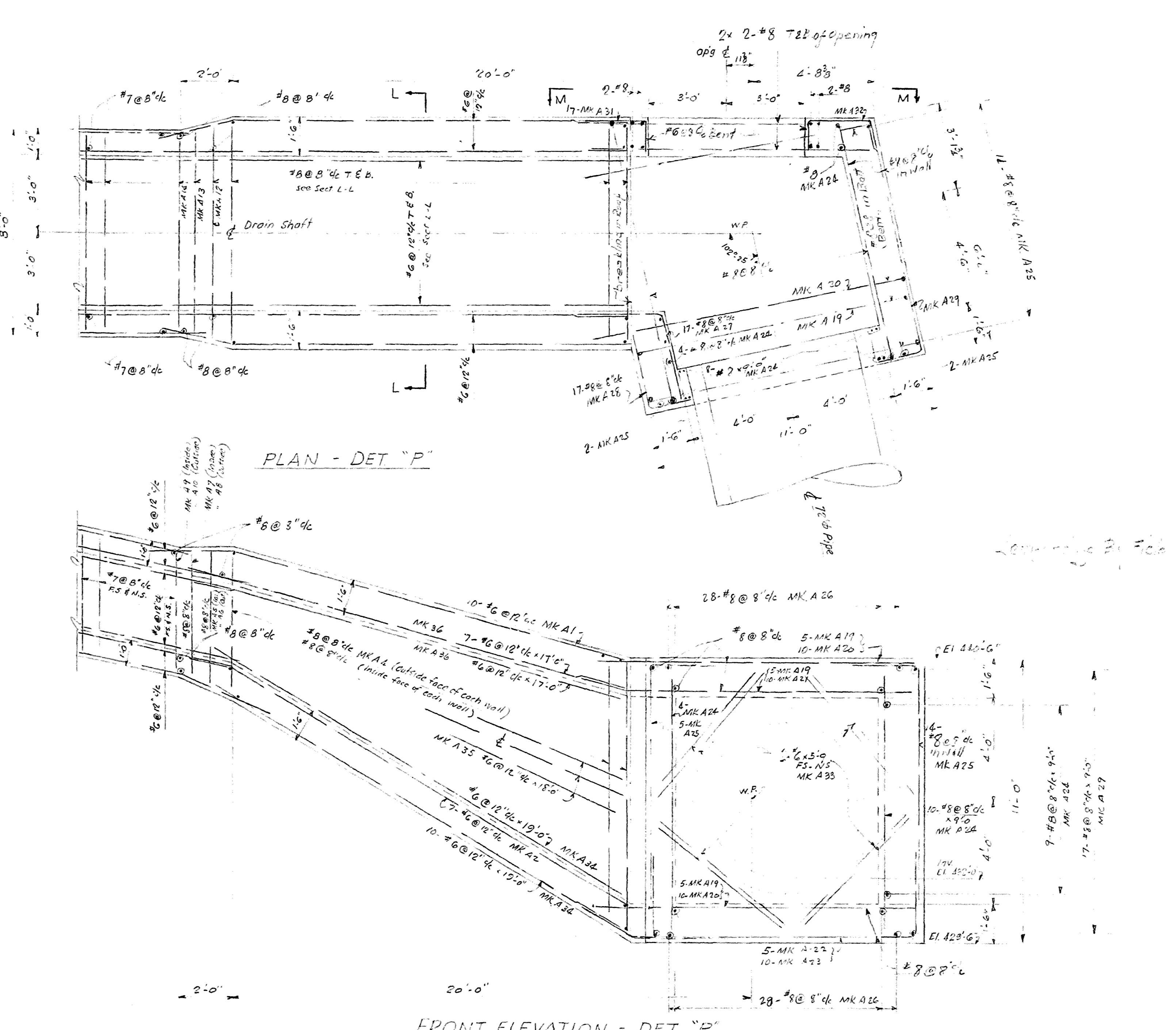
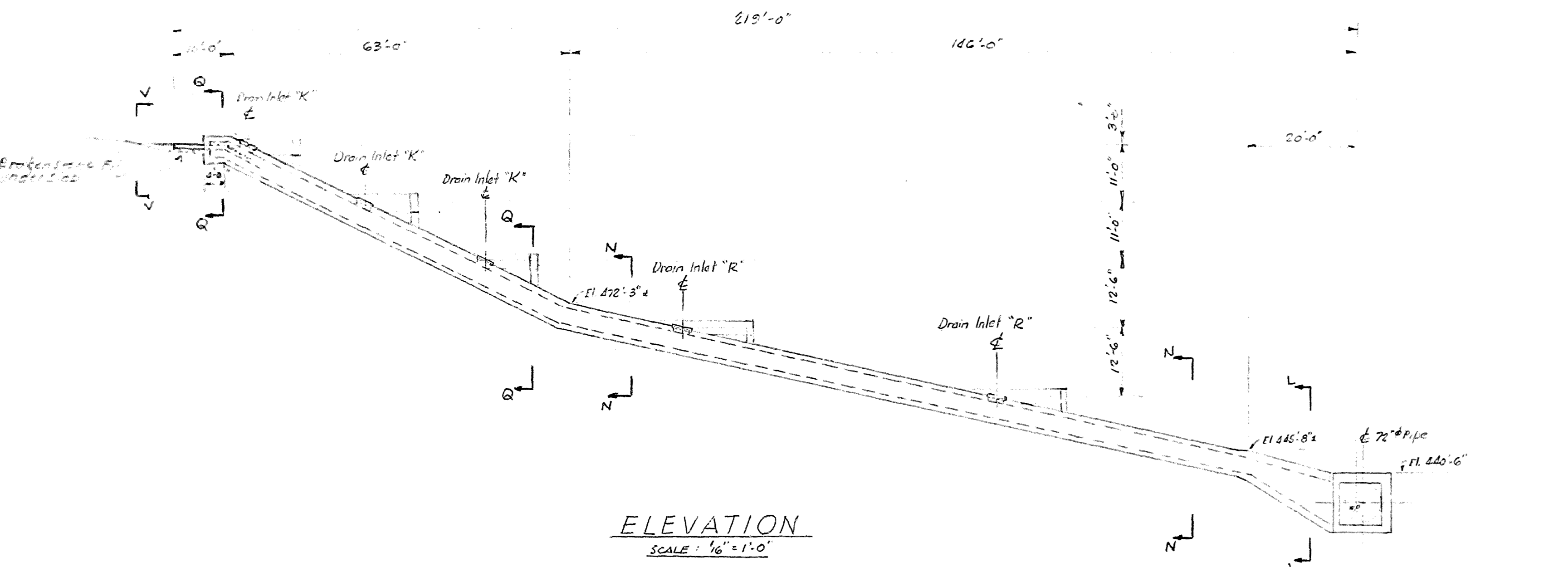
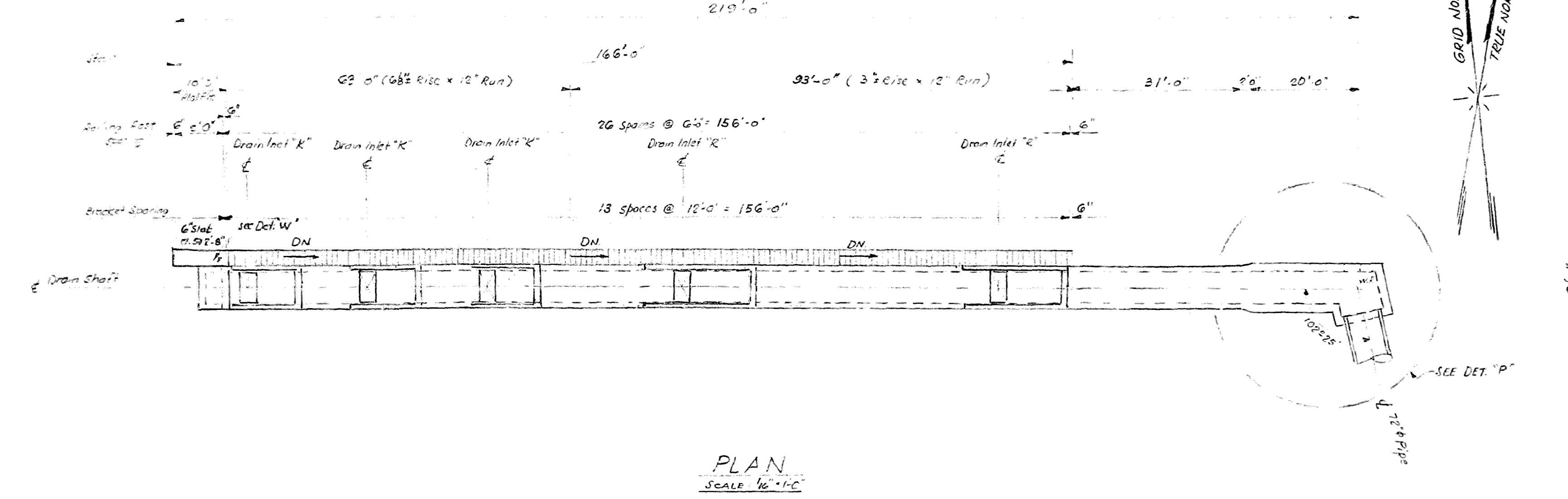

DR. No. 3173 Masonry Details  
RSI SHELLS Reins. Standard

DATE	NO.	DESCRIPTION	APPD.
<b>REVISIONS</b>			
		FLY ASH AREA	
		LOWER EARTH DAM - DRAIN SHAFT	
		REINFORCING DETAILS	
		INDIANA KENTUCKY ELECTRIC CORP.	
		CLIFTY CREEK PLANT	
		MADISON INDIANA	

DR. No. 16-3173

ARCH. ELEC. MECH. STR.

SCALE AS NOTED APPROVED

DR. J.S.  
CH. J.M.  
DATE 7/2/56

*[Signature]*

AMERICAN GAS & ELECTRIC SERVICE CORP.  
30 CHURCH STREET NEW YORK

**ATTACHMENT C**

**INSTRUMENTATION LOCATION MAP**

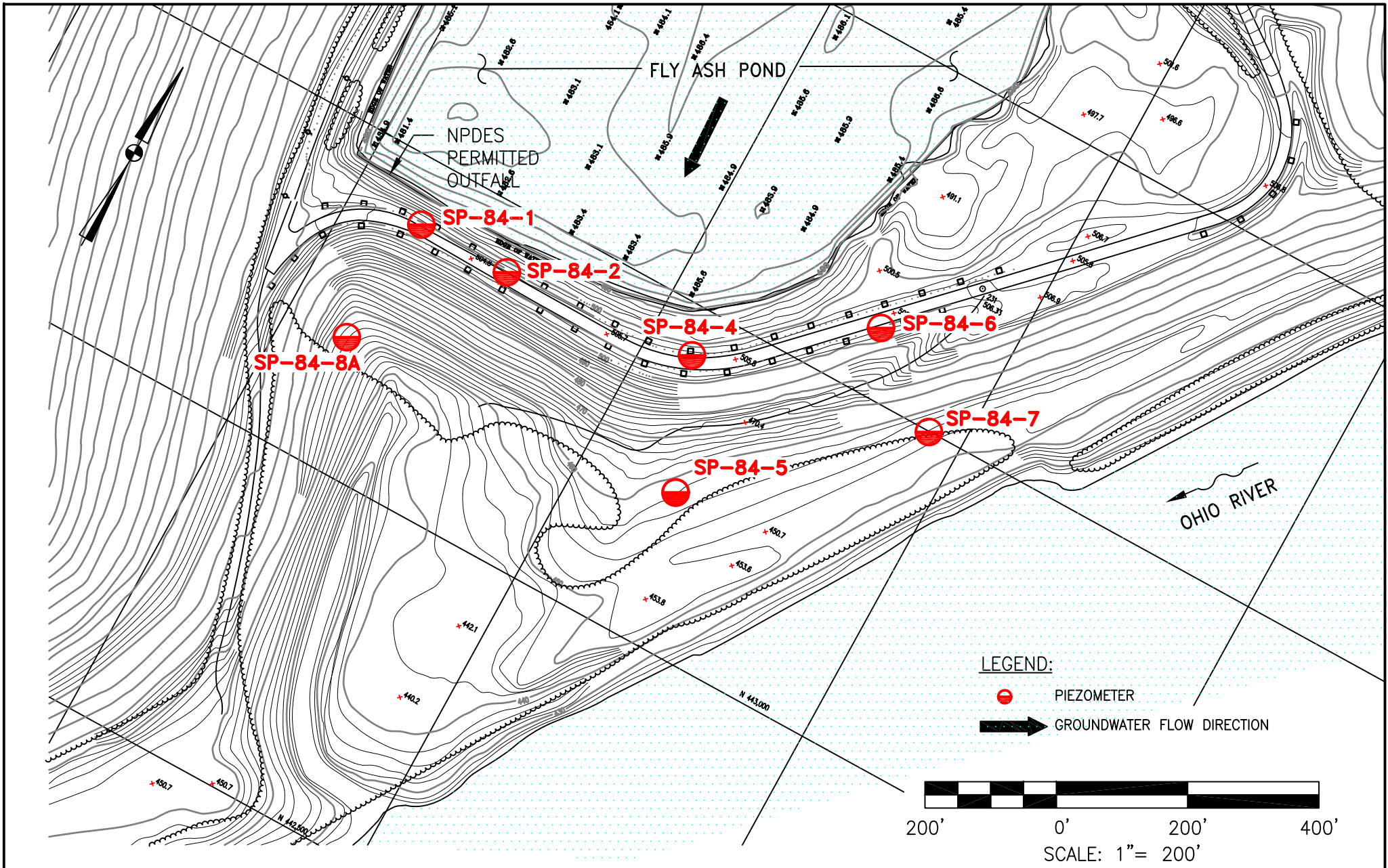

DRAWN BY	JM
DATE	
CHECKED BY	
JOB NO.	P200852-03-IKEC
DWG FILE	CLIFTY CRK PZ Locations a04.dwg
DRAWING SCALE	AS SHOWN

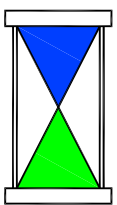

**Applied Geology  
and  
Environmental  
Science, Inc.**  
2402 Hookstown Grade Road  
Suite 200  
Clinton, PA 15026  
(412) 264-6453

INDIANA-KENTUCKY ELECTRIC CORPORATION	
CLIFTY CREEK PLANT MADISON, INDIANA PIEZOMETER LOCATION MAP	
DRAWING NAME	FIGURE 1
REV.	0



**ATTACHMENT D**

**CONSTRUCTION SPECIFICATIONS**

ARTHUR CASAGRANDE  
LEO CASAGRANDE

*Pierce Hall  
Cambridge 38, Massachusetts*

February 10, 1956

Mr. E. A. Kammer, Chief  
Design Division  
American Gas and Electric Service Corporation  
30 Church Street  
New York 8, New York

Subject: Earth Dam for Fly Ash Storage  
for Clifty Creek Plant

Dear Mr. Kammer:

Complying with your request, I visited Clifty Creek on February 8, and I inspected the dam site and proposed borrow areas in the company of Messrs. Brown and Dean, and in addition we reviewed the new design drawings which they had just received from your office. Upon my return, I discussed the pertinent details with my brother and we wish to summarize our impressions and recommendations below.

In view of your decision not to store water to any appreciable height directly against the dam, we have agreed that the original design of a homogeneous clay dam, as outlined in our report to you of September 16, 1955, will be satisfactory.

Preparation of the foundation should consist in removal of all vegetation and of a thin layer of top soil, probably averaging six inches in thickness. It will not be necessary to remove all soil containing some organic material.

Based on our examination and tests of the samples of clay from the proposed borrow areas which we have received during recent weeks, and on my field inspections on August 16, 1955 and February 8, 1956, we conclude that there is an ample volume of suitable clay soils available for the construction of the dam and its dike.

Although we will submit a report on our tests on the samples, we wish to emphasize that the selection of the clay should be based entirely on examination of the consistency by kneading the material by hand. Any clay which is somewhat crumbly, and which cannot be molded like putty, has the right moisture content for placement and compaction. When the clay can be readily molded like putty, it is definitely too wet for compaction. The only practicable method of assuring proper control is to have reliable inspectors on the job while placement and compaction are in progress.

Individual loads of clay which are somewhat too wet, may be placed within the limits of the core as indicated on your drawings by the 45 degree lines. However, one should not make it a practice to place deliberately soft clay into the core because such material cannot be properly compacted.

If it should be found desirable, or necessary, to utilize also the fine, silty sand which is located close to the dam, it should be placed downstream from the 45 degree core limit-line as shown on your drawing. However, this sandy soil cannot be properly compacted by means of a sheepsfoot roller. Therefore, if the contractor elects to compact the clay by means of a sheepsfoot roller, the sandy soil would have to be compacted either by means of a crawler-type tractor or a rubber-tired roller (four wheels abreast) loaded to at least 35 tons.

I was asked whether extra-heavy corrugated Armo-co-pipe would be suitable for the culvert. We consider such a pipe to have the great advantage as compared to concrete pipe, of being able to stretch longitudinally without causing joints to open up. Therefore, we would prefer such a pipe. However, you should check with the manufacturer whether the proposed pipe will withstand the height of fill.

February 10, 1956

Mr. Brown inquired whether I would have any objections against moving the trough onto the natural slope of one of the abutments. We can see no objection to locating the trough onto the natural slope. In fact, it may be advantageous to do so, first because the natural slope is deeper and, therefore, the length of the trough would be reduced; and second, because the natural slope is not subject to settlement, in contrast to the dam, and therefore, the danger of development of cracks in the trough would be substantially reduced.

Very truly yours,

Leo Casagrande

LC/eck

cc: E. T. Snodgrass

J. F. Brown ✓